

Field circuit breakers (excitation contactors) from 80 to 6200 A

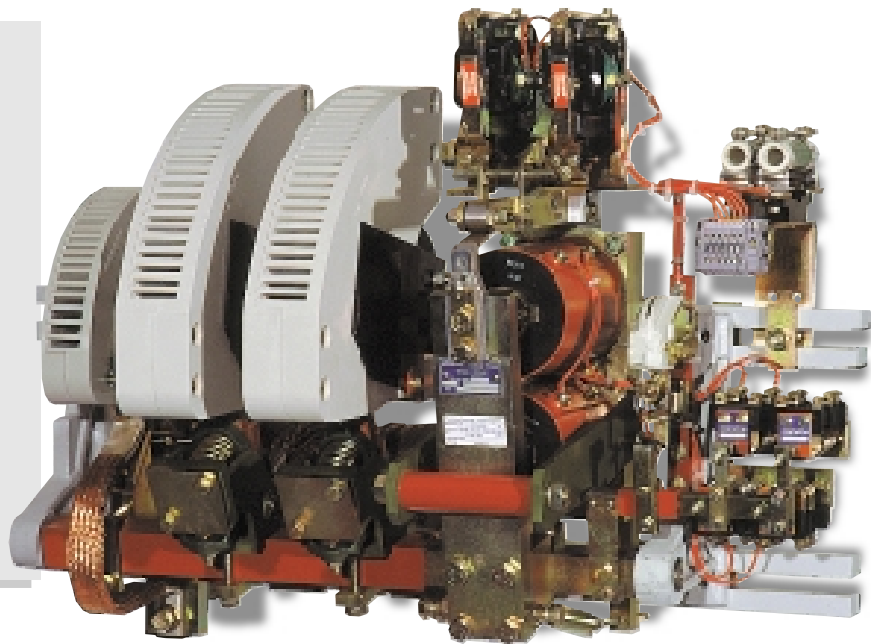

CEX 57 80,
CEX 57 150,
CEX 57 200,
CEX 75 400,
CEX 75 500,
CEX 75 630,
CEX 75 800,
CEX 75 1000,
CEX 71 1250,
CEX 71 1600,
CEX 71 2000,
CEX 98 2560,
CEX 54 3000,
CEX 98 3000,
CEX 98 5000,
CEX 60 5000,
CEX 60 5500,
CEX 60 6200.



CEX 71 1250 2.1
Reinforced insulation

Field circuit breakers - CEX 80 to 6200 A

A1 : complete thyristor bridge.
A2 : thyristor starter.
ALT : alternator.
C1 : contactor for field supply.
EX : inductor.
EXT : static excitation.
Ko : relay for regulation and release.
Rd : discharge resistor.
T1 : excitation transformer.

Use

Switching on and cutting off the excitation circuit of a machine, inserting a discharge resistor at the terminals of the inductor at the time of the break.

The drawing below represents the static excitation circuit of an alternator.

Description

- 1, 2 or 3 magnetic arc-blow-out contactor poles:
 - silver alloy contacts for calibre 80 to 5000 A.
 - copper contacts (on request).
- One magnetic arc-blow-out dosing pole with overlapping with the contactor poles.
- One mechanical latching with single or double electrical release.
- Magnetic circuit for over-excited coil supplied with DC current:
 - closing: economy resistor for calibre 80 to 200 A, delivered separately.
 - opening: one NO contact connected in series with the coil opens at the same time as the contactor.
- Auxiliary contacts:
 - range 80 to 200 A: 1 one M3 block type F102-Y with one NC overlap contact inserting the resistor, one NO contact switching off the tripping coil and one NO contact available.
 - range 400 to 1000 A: two D-blocks, that is 2 NO + 2 NC contacts available and one M3 block type F102-Z with one overlap NC contact inserting the resistor, one NO contact switching off the tripping coil and one contact available.
 - range 1250 to 5000 A: one NC arc-blow-out contact inserting the resistor, one M3 block type F102-Z with one NO contact switching off the tripping coil, 1 NO + 1 NC contacts available.

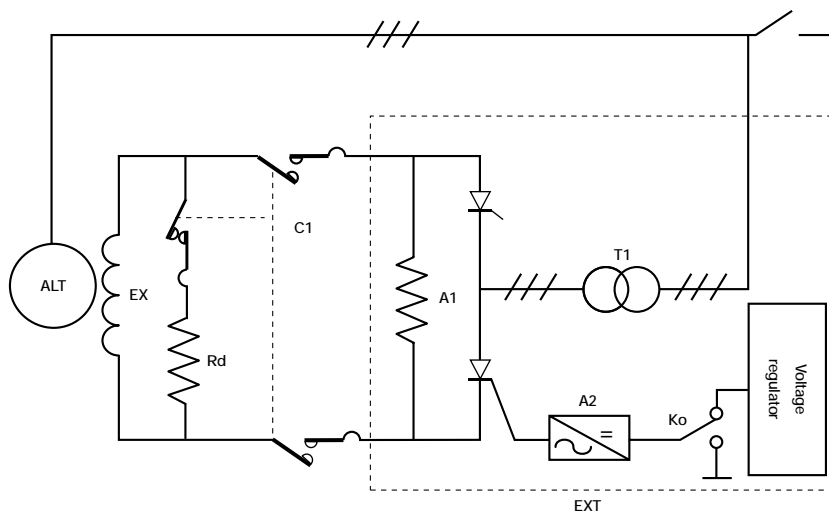

Double CEX

Double CEX contactors (contactors for field supply) ranging from 80 to 1000 A are equipped with a mechanical coupling whereas double CEX contactors ranging from 1250 to 5000 A are equipped with a manual release system.

For a maximum pole switch-off voltage of:
2000 V for range 80 to 200 A,
2200 V for range 400 to 1000 A,
2400 V for range 1250 to 6200 A.



IMPROVED PERFORMANCES

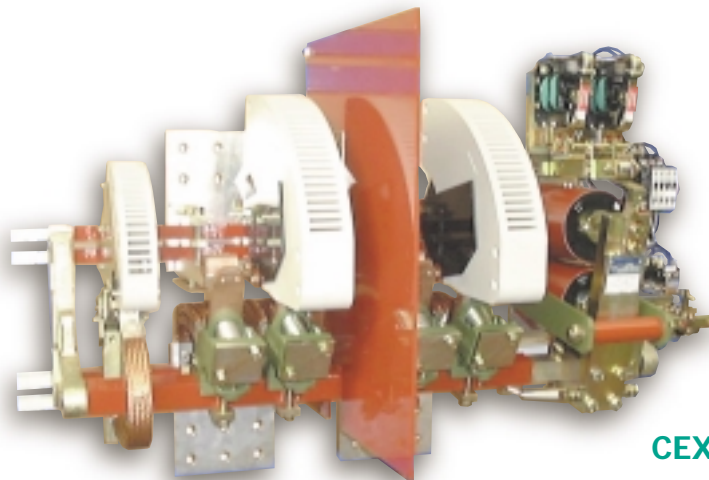

CEX 98 3200 2.1

Contactor pole		80	150	200	400	500	630	800	1000	1250	1600	2000	2560	3200	3000	5000 ⁽¹⁰⁾	5000	5500	6200
Génération		55/57	55/57	55/57	75	75	75	75	75	71	71	71	98	98	54	98	60	60	60
Thermal nominal current	A	80	150	200	400	500	630	800	1000	1250	1600	2000	2560	3200	3000	5000	5000	5500	6200
connecting section	mm ²	35	70	95	240	300	400	500	600	1000	1400	1600	1900	3000	3000	5000	5000	6000	7000
Operating voltage																			
two-pole or single-pole break	V	500	500	500	550	550	550	550	550	600	600	600	600	600	600	600	600	600	600
three-pole break	V	1000	1000	1000	1000	1000	1000	1000	1000	1000	1000	1000	1000	1000	1000	1000			
2 two-pole breaks in series	V	1400	1400	1400	1500	1500	1500	1500	1500	1500	1500	1500	1500	1500	1500	1500	1500	1500	1500
Insulating voltage																			
two-pole or single-pole break	V	5000	5000	5000	5000	5000	5000	5000	5000	5000	5000	5000	5000	5000	5000	5000	5000	5000	5000
three-pole break	V	6250	6250	6250	6250	6250	6250	6250	6250	6250	6250	6250	6250	6250	6250	6250			
2 two-pole breaks in series	V	7500	7500	7500	7500	7500	7500	7500	7500	7500	7500	7500	7500	7500	7500	7500	7500	7500	7500
Short-time current, t ≤ 40°C																			
1 s	kA	1	1.75	2.5	10	12	14	24	26	41	30	65	43		36				
5 s	kA	0.5	0.8	1.15	4.5	5.75	6.5	11	12.5	20	15	30	21.6	43	16	50	25	27	31
10 s	kA	0.35	0.57	0.81	3.25	4	4.5	7.8	8.5	13.5	10.9	21	15.7	30	11.5	40	20	22	24.5
15 s	kA	0.3	0.51	0.7	1.9	2.4	2.7	4.6	5	7.9	6	12	12.5	25.7	9.5	36	15	16.5	18.5
30 s	kA	0.23	0.42	0.56	1.9	2.4	2.7	4.6	5	7.9	6	12	8.6	17.3	7	24	11	12	13.5
1 min	kA	0.19	0.31	0.43	1.4	1.78	2	3.3	3.65	5.5	4.5	8.5	6.5	12.2	5.4	17	8.5	9	10.5
3 min	kA	0.14	0.3	0.4	0.88	1.1	1.3	2	2.3	3.3	3	5	4.3	7.2	4	10	6.5	7	8
10 min	kA	0.12	0.26	0.35	0.62	0.79	0.92	1.38	1.6	2	2.2	3.2	3.1	4.6	3.3	6.5	5.6	6	6.9
Maximum switch-off voltage																			
single-pole break	V	550	550	550	550	550	550	550	550	700	700	700	700	700	600	700	600	600	600
two-pole break	V	1000	1000	1000	1100	1100	1100	1100	1100	1200/1500 ⁽³⁾	1200/1500 ⁽³⁾	1200/1500 ⁽³⁾	1500	1500	1200	1500	1200	1200	1200
three-pole break ⁽¹⁾	V	1500	1500	1500	1500/2000	1500/2000	1500/2000	1500/2000	1500/2000	1500/2100	1500/2100	1500/2100	1500/2100	1500/2100	1500/1800	1500/2100			
four-pole break (2 two-pole breaks in series) ⁽¹⁾	V	2000	2000	2000	2200	2200	2200	2200	2200	3000	3000	3000	3000	3000	2400	3000	2400	2400	2400
Current switch-off rating under a given voltage, with L/R=15 ms⁽¹⁾																			
single-pole break under																			
500 V	kA	0.5	1.4	3.5		8	8												
550 V	kA				6	7	7	18	18										
700 V	kA									15	15	23	23	23	35	23	35	35	35
two-pole break under																			
500 V	kA									32	32	32	32	32	55	32	55	55	55
700 V	kA	0.5	1.4	3.5	6	10	10	17	17	23	23	23	23	23	35	23	35	35	35
1000 V	kA	0.25	0.7	1.75	5	7	7	10	10	19	19	19	19	19	35	19	35	35	35
1500 V ⁽³⁾	kA									6.6	6.6	6.6	6.6	6.6		6.6			
three-pole break under																			
1000 V	kA				6	10	10	17	17	23	23	23	23	23	35	23	35	35	35
1500 V	kA				5	7	7	10	10	19	19	19	19	19	24	19	24	24	24
1800 V	kA				2	2.5	2.5	8	8	14	14	14	14	14	20	14	20	20	20
2000 V	kA				1.5	2	2	6	6	8	8	8	8	8		8			
four-pole break (2 two-pole breaks in series)																			
1000 V	kA									30	30	30	30	30	55	30	55	55	55
2000 V	kA	0.25	0.7	1.75	5	7	7	10	10	19	19	19	19	19	35	19	35	35	35
3000 V	kA									5	5	5	5	5		5			

(1) maximum switch-off voltage is directly linked to the current to cut off, as well as to the different configurations (single-pole, two-pole, three-pole breaks, 2 two-pole break in series). In order to choose the best contactor, please consult our technical department.
 (2) 500 A and 1000 A, on request.
 (3) dimensions given with separator between the poles.
 (4) one single control circuit.
 (5) standard ratings for rupturing pole:

rupturing pole rating	CEX 98 2560/3000 type of break (number of blow-out poles)	CEX 98 5000 type of break (number of blow-out poles)	Maximum switch-off voltage (V)
500 ⁽⁷⁾	1	1	700
500 ⁽⁷⁾	2	2	1500
800		2 ⁽⁶⁾	1500
500 ⁽⁷⁾	3	3	2100
800	4	4	3000

(6) two pole break: one break on each line.
 (7) 800 A, on request.
 (8) average consumption under 220 V. For other voltages, consult us.
 (9) average consumption under 220 V with single pole or two-pole break on a single line only. For other voltages, consult us.
 (10) for 5500 A, lower section C = 15 mm.

• Temperature factor to apply to the power or to the current controlled according to the ambient temperature (around the contactor). For ranges 80 to 2000 A, 54-3000, 60-5000, 60-5500 and 60-6200 A, no derating up to 55° C.

1.04	40 < t < 45°C
1.08	45 < t ≤ 50°C
1.12	50 < t ≤ 55°C
1.19	55 < t ≤ 60°C



NEW

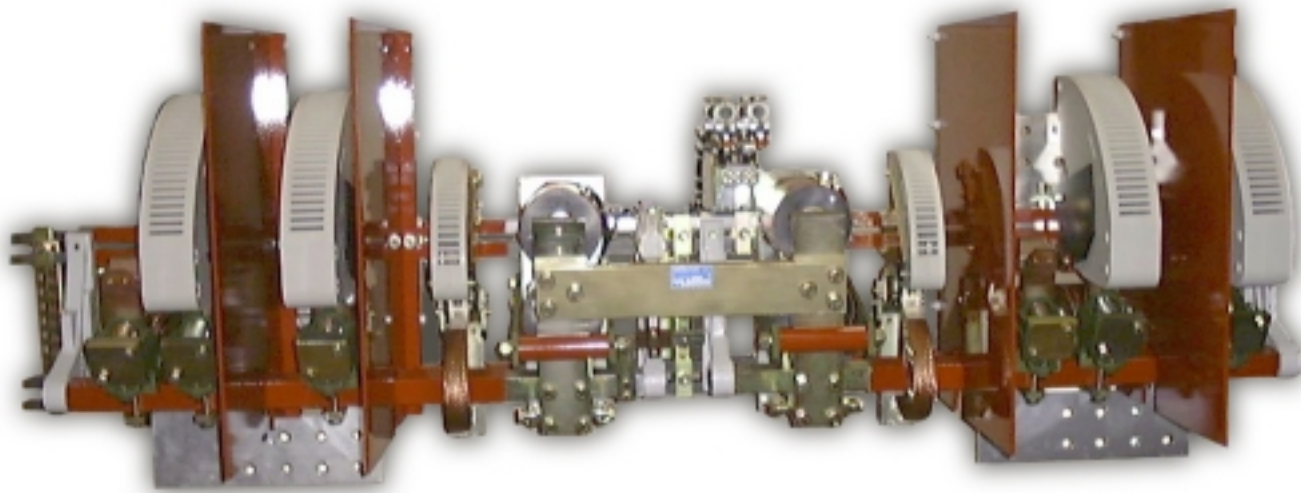

CEX 98 3200 4.2

Contactor pole	80	150	200	400	500	630	800	1000	1250	1600	2000	2560	3200	3000	5000 ⁽¹⁾	5000	5500	6200
Génération	55/57	55/57	55/57	75	75	75	75	75	71	71	71	98	98	54	98	60	60	60

Rupturing pole

Thermal nominal current	A	80	80	150	400	400	400	400	400	500	500	500	500/800 ⁽⁵⁾	500/800 ⁽⁵⁾	800 ⁽²⁾	500/800 ⁽⁵⁾	800 ⁽²⁾	800 ⁽²⁾	800 ⁽²⁾
Current-switch-on rating	kA	0.5	0.5	1.4	6	6	6	6	6	8	8	8	8/10	8/10	10	8/10	10	10	10
Allowable current for 15 s	kA	0.35	0.35	0.8	3.5	3.5	3.5	3.5	3.5	5	5	5	5/9.5	5/9.5	9.5	5/9.5	9.5	9.5	9.5
Allowable current for 0.5 s	kA	1	1	1.75	4.5	4.5	4.5	4.5	4.5	6.5	6.5	6.5	6.5/12	6.5/12	12	6.5/12	12	12	12
Resistive current switch-off rating	kA	0.25	0.25	0.7	6	6	6	6	6	8	8	8	8/10	8/10	10	8/10	10	10	10

Control circuit

Standard voltages	V	24 - 48 - 110 125/127 - 220 - 440																	
Average consumption																			
on closing																			
single-pole or two-pole break																			
inrush	W	43	43	77	500	500	500	800	800	500	500	500	3145 ⁽⁸⁾	3145 ⁽⁸⁾	1000	3145 ⁽⁹⁾	2600	2600	2600
hold	W	43	43	43	30	30	30	70	70	42	42	42	225 ⁽⁸⁾	225 ⁽⁸⁾	66	225 ⁽⁹⁾	145	145	145
three-pole break																			
inrush	W	43	195	195	525	525	525	850	850	1600 ⁽⁸⁾	1600 ⁽⁸⁾	1600 ⁽⁸⁾			1100	3370 ⁽⁸⁾			
hold	W	43	74	74	35	35	35	75	75	110 ⁽⁸⁾	110 ⁽⁸⁾	110 ⁽⁸⁾			72	350 ⁽⁸⁾			
2 two-pole breaks in series																			
inrush	W	43 ⁽⁴⁾	86	154	1000	1000	1000	1600	1600	1000	1000	1000	3370 ⁽⁸⁾	3370 ⁽⁸⁾	2000		5200	5200	5200
hold	W	43 ⁽⁴⁾	86	86	60	60	60	140	140	84	84	84	350 ⁽⁸⁾	350 ⁽⁸⁾	132		290	290	290
on opening																			
single-pole, two-pole or three-pole break	W	220	220	220	220	220	220	220	220	220	220	220			220		220	220	220
2 two-pole breaks in series	W	220 ⁽⁴⁾	440	440	440	440	440	440	440	440	440	440			440		440	440	440
Opening time	ms	25	25	25	50	50	50	50	50	60	60	60	90	90	60	70	60	60	60
Closing time	ms	180	180	180	125	125	125	125	125	300	300	300	300	300	300	300	300	300	300
Constant L/R rate of closed electromagnet	ms	140	140	40	40	40	40	40	40	40	40	40			50		50	50	50
Total break time	ms	50	50	50	70	70	70	70	70	85	85	85	90	90	85	90	85	85	85

(1) maximum switch-off voltage is directly linked to the current to cut off, as well as to the different configurations (single-pole, two-pole, three-pole breaks, 2 two-pole break in series).
In order to choose the best contactor, please consult our technical department.

(2) 500 A and 1000 A, on request.

(3) dimensions given with separator between the poles.

(4) one single control circuit.

(5) standard ratings for rupturing pole :

rupturing pole rating	CEX 98 2560/3000 type of break (number of blow-out poles)	CEX 98 5000 type of break (number of blow-out poles)	Maximum switch-off voltage (V)
500 ⁽⁷⁾	1	1	700
500 ⁽⁷⁾	2	2	1500
800		2 ⁽⁶⁾	1500
500 ⁽⁷⁾	3	3	2100
800	4	4	3000

(6) two pole break: one break on each line.

(7) 800 A, on request.

(8) average consumption under 220 V.

For other voltages, consult us.

(9) average consumption under 220 V with single pole or two-pole break on a single line only.

For other voltages, consult us.

(10) for 5500 A, lower section C = 15 mm.

• Temperature factor to apply to the power or to the current controlled according to the ambient temperature (around the contactor).
For ranges 80 to 2000 A, 54-3000, 60-5000, 60-5500 and 60-6200 A, no derating up to 55° C.

1.04	40 < t < 45° C
1.08	45 < t ≤ 50° C
1.12	50 < t ≤ 55° C
1.19	55 < t ≤ 60° C



NEW

54. DRAW-OUT EXCITATION CONTACTORS

Draw-out version provided
for generation 71 from 1250 to 2000 and for generation 98 from 2560 to 5500 A

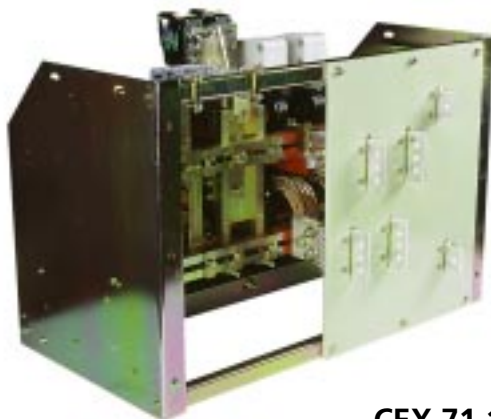
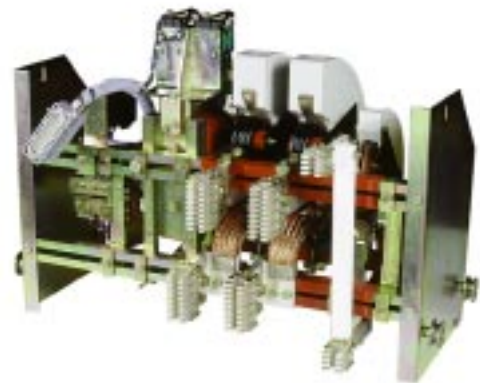

CEX 71 1250 to 2000 2. 1 in draw-out version